

Advanced Lensometry



Welcome

This course is presented in partnership with the United Opticians Association and its member schools. We are proud to bring this hands-on advanced lensometry workshop to you.

This course is designed for professionals who already have a solid working knowledge of basic lensometry. Today, we move beyond simple neutralization and add identification. Our focus is on real-world verification — the skills required to evaluate finished eyewear accurately and confidently.

Throughout this session, you will work directly with manual lensometers and finished eyewear to:

- *Interpret horizontal and vertical prism layout*
- *Apply ANSI tolerance standards during verification*
- *Identify induced prism resulting from decentration*
- *Distinguish prescription error from fabrication error*
- *Make informed remake-versus-adjust decisions*

This is an active workshop. You will measure, calculate, compare findings, and apply professional judgment in structured exercises designed to strengthen both precision and confidence.

Several formal educators are serving as co-instructors during this session. If you need clarification or assistance at any point, please ask.

At the conclusion of this course, you will be invited to provide feedback. Your input helps us continue improving and refining future workshops.

We hope you find this session both challenging and practical.

This workbook is our gift to you. Please keep it as a reference as you continue developing your verification skills.

Advanced Lensometry



Manual Lensometer Reticle Variations

Manual lensometers vary by manufacturer and model. While the principles of neutralization and prism measurement remain constant, reticle design, scale markings, and illumination may differ. As a verifying professional, you must be able to interpret prism and power accurately regardless of the reticle style in front of you.

Before measuring prism on any unfamiliar lensometer, always pause and assess the reticle design.

When using a lensometer, always identify:

- Sphere Lines (Primary Mire)
- Cylinder Lines (Secondary Mire)
- Prism Scale / Ring Value
- Axis Reference Scale

Here are some common examples:

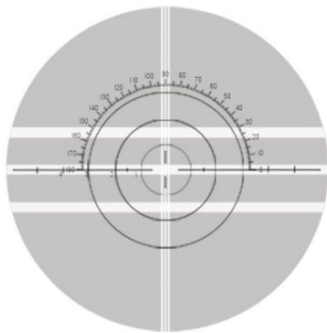

Reticle Example # 1

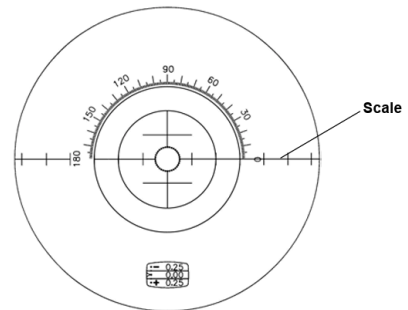

Reticle Example # 2

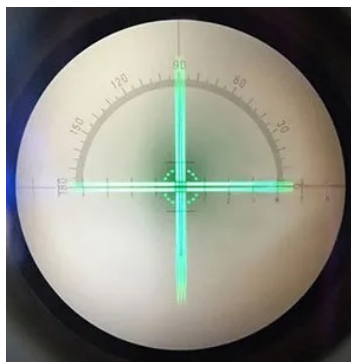

Reticle Example # 3

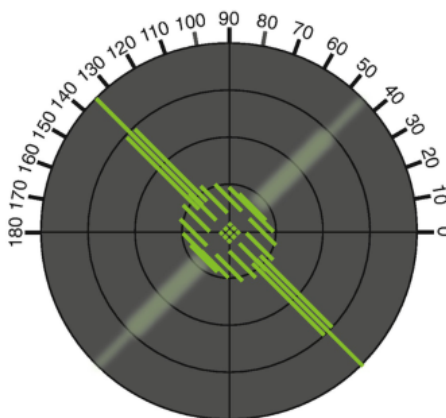

Reticle Example # 4

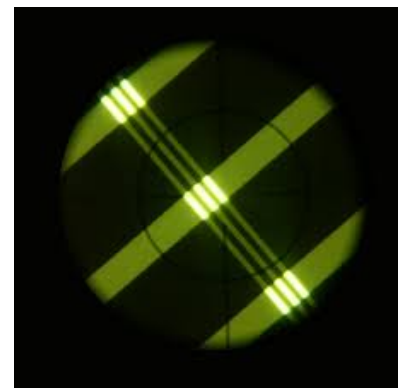

Reticle Example # 5

Advanced Lensometry



Prism Layout Review - Foundational

In your kits, you will find a printed reticle in your packet.

We will use these materials to review the layout of prism before we begin evaluating finished eyewear.

For this exercise, all participants will use the same standard concentric ring reticle to ensure a consistent reference point. Try to complete them first. We will then show the answers on the screen. If you have questions, please raise your hand and an instructor will assist you.

Practice Problems

Complete for both right and left eye!

Horizontal Prism

- 1 Δ Base In (BI)
- 1 Δ Base Out (BO)

Vertical Prism

- 1 Δ Base Up (BU)
- 1 Δ Base Down (BD)

Compound Prism

- 3 Δ Base Up and 3 Δ Base In (OD)
- 2 Δ Base Down and 3 Δ Base In (OD)
- 3 Base Up and 1.5 Δ Base In (OS)
- 2 Δ Base Down and 0.50 Δ Base In (OS)

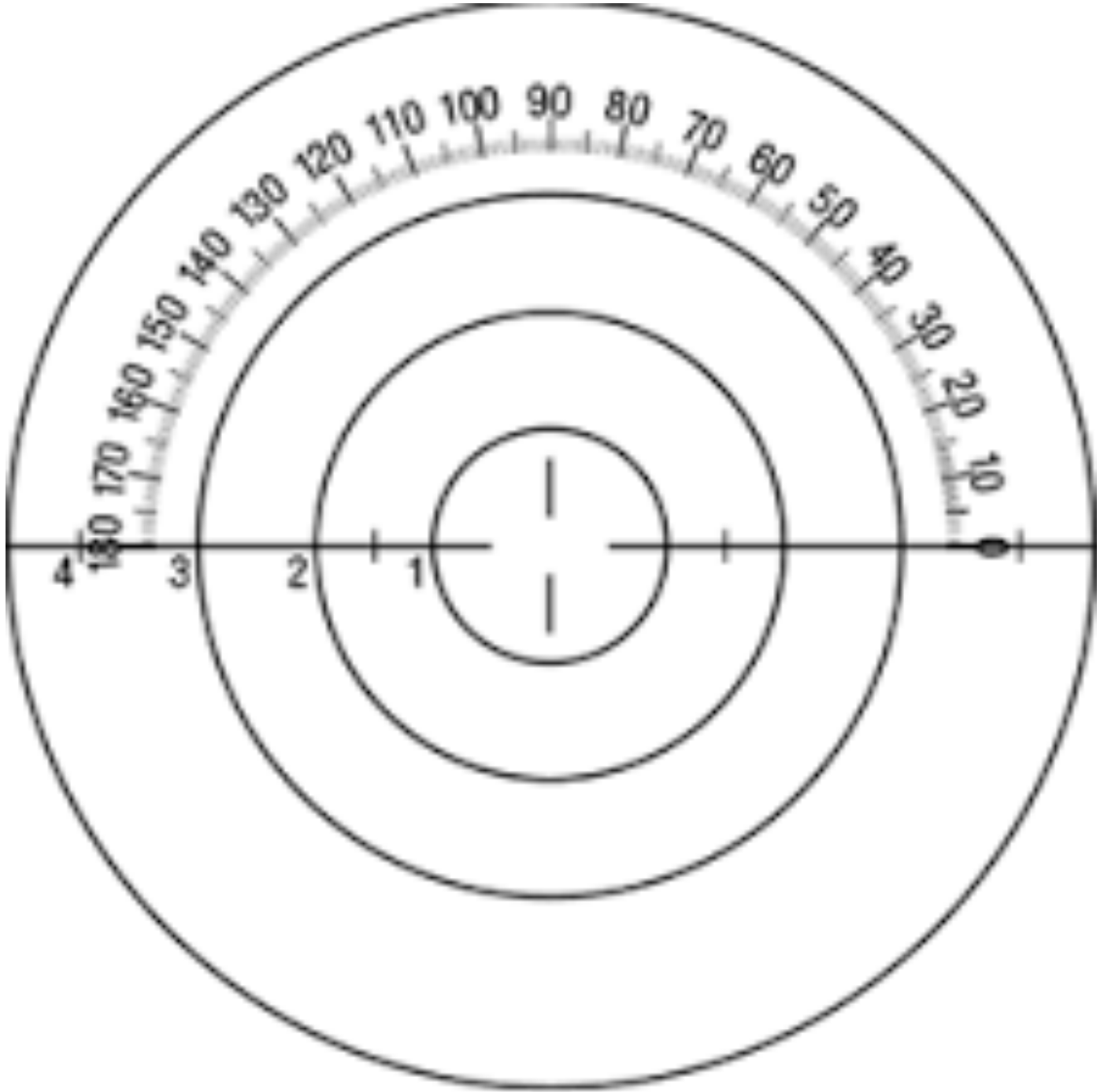

Advanced Lensometry



Prism Layout – Lensometer Application

Now that we have reviewed the fundamentals on paper, let's apply them using a real lensometer.

Over the next 15 minutes, you will use each lens to lay out prism at the specified axes and prism amounts listed below. The lens power is intentionally not provided, as each participant's lens will vary. Using the lensometer at your station and the materials in your kit, locate your two loose lenses. Both have cylinder one is a plus lens and one is a minus lens. Using the 8 examples below, set up the lenses to the axis and prism.

Your goal is to:

- Neutralize the lens
- Induce the specified prism
- Lay out the mire displacement correctly
- Identify the vertical and/or horizontal components

If you finish early, raise your hand and additional lenses will be provided for continued practice.

Instructors will be circulating throughout the room. If you encounter any challenges, please raise your hand for assistance.

Example 1 – Simple

- Axis: 090
- Prism: OD 1Δ Base In

Example 2 – Simple

- Axis: 180
- Prism: 2Δ Base Down

Example 3 – Compound

- Axis: 045
- Prism: OS 1Δ Base Up and 2Δ Base Out

Example 4 – Compound

- Axis: 135
- Prism: OD 2Δ Base Down and 3Δ Base In

Example 5 – Simple

- Axis: 090
- Prism: OD 1Δ Base Out

Example 6 – Simple

- Axis: 180
- Prism: OS 2Δ Base Up

Example 7 – Compound

- Axis: 060
- Prism: OS 1Δ Base Down and 2Δ Base Out

Example 8 – Compound

- Axis: 120
- Prism: OS 2Δ Base Up and 3Δ Base In

Example 9 – Compound

- Axis: 180
- Prism: OD 2Δ @ 45°

Example 10 – Compound

- Axis: 090
- Prism: OD 2Δ @ 45°

Reflection Questions

1. Did the base direction change when switching from minus to plus lens types?
2. How did axis orientation affect your prism layout?
3. Why is understanding induced prism essential when verifying finished eyewear?

Advanced Lensometry

Verification

Now that we have reviewed lensometry fundamentals and how to neutralize lenses, we will transition into verification.

Verification is the process of confirming that finished eyewear:

- Matches the prescribed Rx
- Falls within acceptable tolerance ranges
- Is properly aligned and mounted
- Meets professional standards before being released to a patient

Neutralizing tells us what a lens measures.

Verification tells us whether the job is acceptable.

As professionals, it is our responsibility to evaluate the entire job — from prescription accuracy to physical alignment.

ANSI Standards - Applying Power Standards

For each prescription below:

Below we have 4 prescription. Using the ANSI Standards on the screen, answer the following questions.

- What is the allowable sphere tolerance?
- What is the allowable cylinder tolerance?
- What is the allowable axis tolerance?
- Does this lens pass or fail?

Advanced Lensometry

Problem # 1: Single Vision

- Ordered:
+2.00 -1.00 × 180
- Measured:
+2.12 -1.00 × 182
- What is the allowable sphere tolerance?
- What is the allowable cylinder tolerance?
- What is the allowable axis tolerance?
- Does this lens pass or fail?

Problem # 3: Trifocal

- Ordered:
Plano -0.50 × 090 Add +2.00
- Measured:
+0.12 -0.62 × 088 Add +2.12
- What is the allowable sphere tolerance?
- What is the allowable cylinder tolerance?
- What is the allowable axis tolerance?
- Does this lens pass or fail?

Problem # 2: Bifocal

- Ordered:
-7.00 -1.50 × 090 Add +2.50
- Measured:
-6.88 -1.62 × 095 Add +2.37
- What is the allowable sphere tolerance?
- What is the allowable cylinder tolerance?
- What is the allowable axis tolerance?
- Does this lens pass or fail?

Problem # 4: Progressive

- Ordered:
-12.00 -2.00 × 090 Add +2.25
- Measured:
-11.75 -1.87 × 091 Add +2.37
- What is the allowable sphere tolerance?
- What is the allowable cylinder tolerance?
- What is the allowable axis tolerance?
- Does this lens pass or fail?

Advanced Lensometry



ANSI Standards - Calculating Vertical Imbalance

Prism Imbalance Math Problems

Directions: For each case, calculate the vertical prism imbalance and/or horizontal prism imbalance at the prism reference point. Then determine Pass / Fail using the verification limits for the lens type.

Problem # 1 — Single Vision (Mounted Pair)

OD prism: $0.50\Delta BD$

OS prism: $0.25\Delta BD$

Vertical imbalance = _____ Δ

Pass / Fail = _____

Problem # 3 — Segmented Lenses (Mounted Pair)

OD prism: $0.50\Delta BI$

OS prism: $1.00\Delta BI$

Horizontal imbalance = _____ Δ

Pass / Fail = _____

Problem # 2 — Single Vision (Mounted Pair)

OD prism: $0.25\Delta BU$

OS prism: $0.25\Delta BD$

Vertical imbalance = _____ Δ

Pass / Fail = _____

Problem # 4 — Progressive Addition Lenses (Mounted Pair)

OD prism: $0.50\Delta BD$

OS prism: $1.00\Delta BD$

Vertical imbalance = _____ Δ

Pass / Fail = _____

Advanced Lensometry



Prentice's Rule Prism-Imbalance Problems

Dd/10

D = Power
d = deviation

Problem 1 — Single Vision (Horizontal Imbalance)

Rx OU: -4.00 DS
Monocular PD ordered: 32/32
Monocular PD measured in glasses: 31/33

OD prism: _____ Δ (BI/BO)
OS prism: _____ Δ (BI/BO)
Horizontal imbalance: _____ Δ

Problem 2 — Single Vision (Vertical Imbalance)

Rx OU: +3.00 DS
OC height ordered: 20 mm OU
OC height measured: OD 18 mm, OS 22 mm

OD prism: _____ Δ (BU/BD)
OS prism: _____ Δ (BU/BD)
Vertical imbalance: _____ Δ

Problem 3 — Single Vision (Vertical + Horizontal Imbalance, Oblique Cyl)

Rx
OD: +4.00 -2.00 × 030
OS: +3.00 -3.00 × 120

OC height ordered: 20 mm OU
OC height measured: OD 18 mm, OS 22 mm

Monocular OC (x-position) ordered: 32 mm OD /
32 mm OS
Monocular OC (x-position) measured: OD 34
mm, OS 30 mm

OD prism:
Vertical: _____ Δ (BU/BD)
Horizontal: _____ Δ (BI/BO)
OS prism:
Vertical: _____ Δ (BU/BD)
Horizontal: _____ Δ (BI/BO)
Vertical imbalance: _____ Δ
Horizontal imbalance: _____ Δ

Advanced Lensometry



Lensometer Application (Hands-On)

Using the lensometer at your station choose the spectacles labeled # 1 and answer the questions

Pair # 1: We ordered with a pupillary distance of 60. Do these glasses pass inspection?

Pair # 2: We ordered this bifocal with segment height of 20 mm. Do these glasses pass inspection?

Pair # 3: We ordered this progressive addition lenses with a mono Pd 33/31. Do these glasses pass inspection?

Advanced Lensometry



Lensometer Application (Hands-On)

Using the lensometer at your station choose the spectacles labeled # 1 and answer the questions

Pair # 1: We ordered with a pupillary distance of 60. Do these glasses pass inspection?

Pair # 2: We ordered this bifocal with segment height of 20 mm. Do these glasses pass inspection?

Pair # 3: We ordered this progressive addition lenses with a mono Pd 33/31. Do these glasses pass inspection?

Advanced Lensometry



Bonus Problem # 1

Ordered:

OD -2.00 -1.00 × 090

OS -2.00 -1.00 × 090

PD 64

Measured (example outcome):

OD -2.12 -1.00 × 092

OS -2.00 -1.12 × 088

PD 65

Pass or Fail? _____

Bonus Problem # 3

Ordered:

OD -4.00 DS

OS -4.00 DS

PD 60

Measured:

OC height OD 2 mm higher than OS

Calculate induced prism.

Vertical imbalance: _____

Pass or Fail? _____

Bonus Problem # 2

Ordered:

OD +3.00 -2.00 × 180

OS +3.00 -2.00 × 180

PD 62

Measured:

OD +3.25 -2.25 × 175

OS +3.12 -2.00 × 183

PD 62

Pass or Fail? _____

Bonus Problem # 4

Ordered:

OD -3.00 -1.00 × 045

OS -3.00 -1.00 × 045

PD 64

Measured PD in glasses: 67

Calculate induced prism per eye.

Horizontal imbalance: _____

Pass or Fail? _____

Advanced Lensometry

ADVANCED LENSOMETRY

Precision. Verification. Accountability.

Thank you for your active participation in today's hands-on Advanced Lensometry workshop, presented with the support of the United Opticians Association Formal Education Members.

Advanced lensometry is not simply about reading power — it is about applying ANSI standards, interpreting results accurately, and making informed professional decisions. Precision in verification directly impacts patient outcomes, compliance, and trust.

Continue practicing with intention. Use the remaining pages in this workbook as your structured reference guide — including the answer key and step-by-step verification framework — to reinforce today's exercises.

Mastery is built through repetition, tolerance awareness, and disciplined technique.

Please take a moment to complete the course evaluation so we can continue refining future workshops.

If you have questions after today's session, feel free to reach out at any time.

George J. Bourque, ABOM, NCLE, LDO
george@franklincummings.edu

